

781D

**High-speed computer button sewing
machine control system**

Instruction

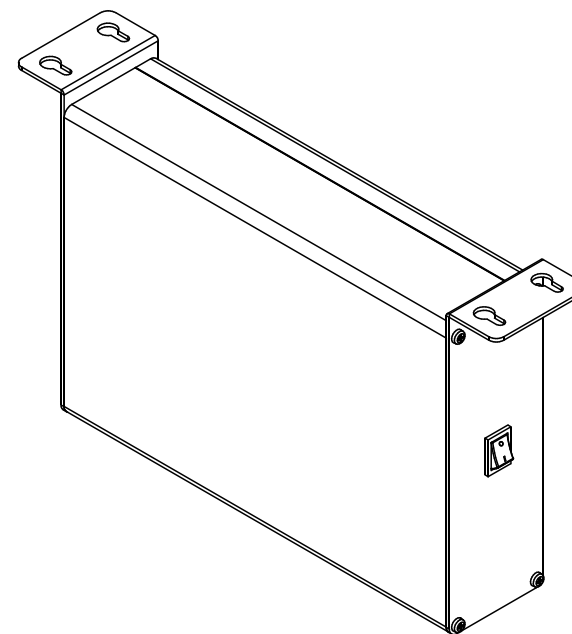

In order to safely use this product, please read this manual carefully before using

Directory

I 、 Safety Instruction	1
II 、 Product Specification	2
1.Product type definition	2
2. Use of environmental requirement	2
3. Product specification	2
4. Accessories configuration list	2
III 、 Installation Instruction	3
1. Installation step	3
2. Control box dimension	3
3. Machine installation diagram	3
4. Direct drive motor and handwheel installation	4
IV 、 Basic Operation	4
V 、 Parameter Setting	5
1. How to enter area A user parameter	6
2. How to enter area B system parameter	6
3. Instruction for using parameter setting panel button	6
4. Parameter setting example	8
5. Special feature	9
6. The default parameter are restored	9
Appendix 1.Operation Panel	10
1. Parameter number selection screen	10
2. Content modification interface parameter	10
Appendix 2.Seven segment display font and font actual value comparison table	11
1. Digital fonts section	11
2. English fonts section	11
Appendix 3.Power line connection method	12
1. Single-phase 220V power supply wiring method	12
2. Three phase four-wire 380V power line wiring method	12
Appendix 4.Terminal Block Function Chart	13
Appendix 5.System function parameter list	14
1. User parameter A area	14
2.System parameter B area	14
Appendix 6.System failure alarm code and trouble operation	16
Appendix 7.Packing list	18
Appendix 8.The appearance of the product cleaning instruction	18
Appendix 9.Description of the product casing open	19
Appendix 10.Replacement parts for this product declaration	19

I 、 Safety Instruction

1. Installing and using this product, the user must carefully read this manual by trained personnel properly trained to install or operate.
2. Installation must be closed when all power, remember not live operation.
3. In connecting the power cord, you must determine the operating voltage specified in this manual comply with the rated voltage value.
4. Power cord grounding wire to find the appropriate size wire and connector and connected to the plant system ground line, this connection must be permanently fixed and secure.
5. Rotating mechanism can be configured protective cover device when operate the machines.
6. The installation is complete after the first power, turn off the trimmer function, light step front pedal low operating the sewing machine and check the correct rotation direction, rotation is stable.
7. During the following operations, turn off the system power supply:
 - 1) Handling motors, controllers, and any connection plug;
 - 2) Raising the sewing machine head and thread the machine;
 - 3) Repair or make any mechanical adjustments on;
 - 4) When the machine is idle.
8. Repair or maintenance of a high level, can only be performed by trained technical person to perform electrical and mechanical.
9. All repair parts supplied or approved by the Company, before use.
10. Use of this product, please away from the electromagnetic and radio frequency transmitters, etc., in order to avoid electromagnetic interference generated by the servo drive unit malfunction.

Danger and caution signs:

In the specification and the machine marked with this symbol, which means that if the error operation may bring damage to the human body or the machine hazard warning
Warning for high voltage :

There are all the instructions and the prompt action must be strictly in accordance with the operating manual required to perform in order to avoid unnecessary harm.

Warranty issues:

The product under normal use and none for operator error in the premise, to ensure the use one year or sale of one and a half year, the impermanence of maintenance services for customers to do.

II 、 Product Specification

1.Product Type Definition

781D: High-speed computer button hole machine control system

2.Use of environmental requirements

- 1) Normal operating temperature: 0 ~ 45°C
- 2) Product storage temperature: -20 ~ 70°C
- 3) Normal working environment humidity: 10% ~90% (no coagulation)
- 4) Rated voltage: 220V±10% 50 (60) HZ
- 5) System ground: < 10Ω
- 6) Work environment: this system working environment should not contain

flammable, explosive, toxic, or corrosive media mist.

3. Product Specifications

- 1) Motor output power:500W
- 2) Sewing speed:200~1500r/min can be set
- 3) Control method: CVT, constant speed operation can be automatically
- 4) Solenoid output signal: One road, presser foot lift solenoid-driven
- 5) Fault protection: stuck, over current, short circuit, overvoltage, power off, etc.
- 6) Stuck protection judgment time 2 seconds;

Synchronizer (locator): Optional configuration in the configuration synchronizer circumstances, to achieve fixed-inch (stitch number) sewing needle stop position; without synchronizer circumstances, to achieve infinitely variable, but can not achieve positioning parking and fixed-inch stitching sewing.

4. Accessories configuration list

Follow "Packing List" carefully check the box for the product accessories, as soon as possible if something is missing please contact with suppliers.

III 、 Installation Instructions

1. Installation Steps

One step: installation of control box and motor

Two steps: installation of the pedal body

Three steps: installation of the operation panel

Four steps: switch box, the installation of the system ground wire

2. Control box dimensions

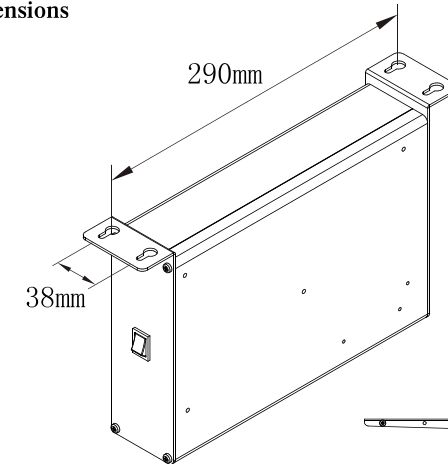

3. Machine installation diagram

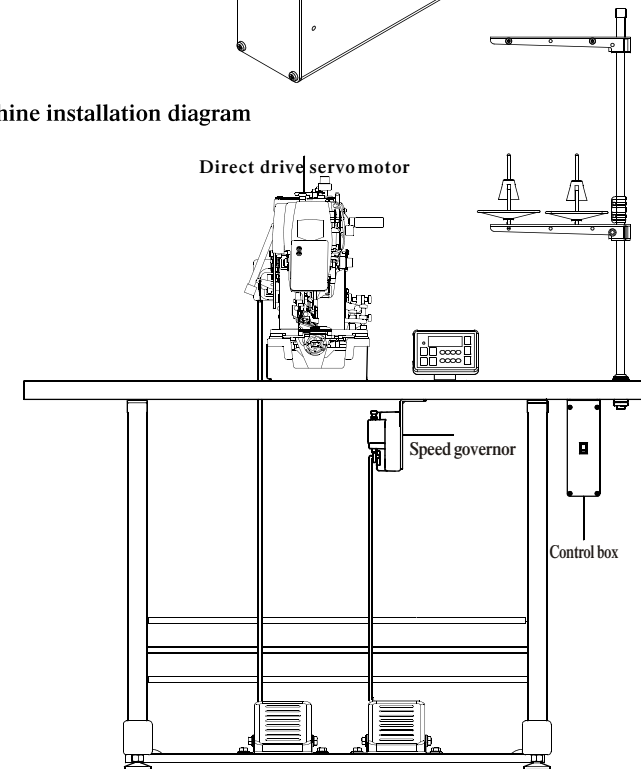

4. Installation of direct drive motor and hand wheel

Motor is mounted to the motor shaft mounted hand "flat" point machine upper axis positioning "flat" position in a straight line installation. Figure: A to align A to install the handwheel positioning block to the first positioning holes on the motor "flat" Installatioⁿ

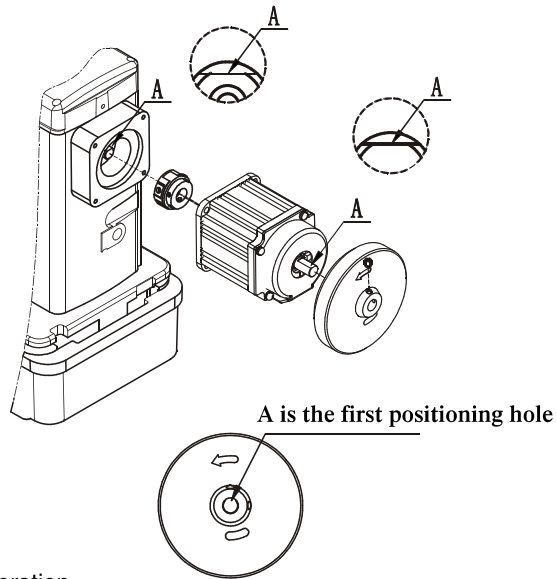

IV、 Basic Operation

Schematic of buttonhole machine operator panel

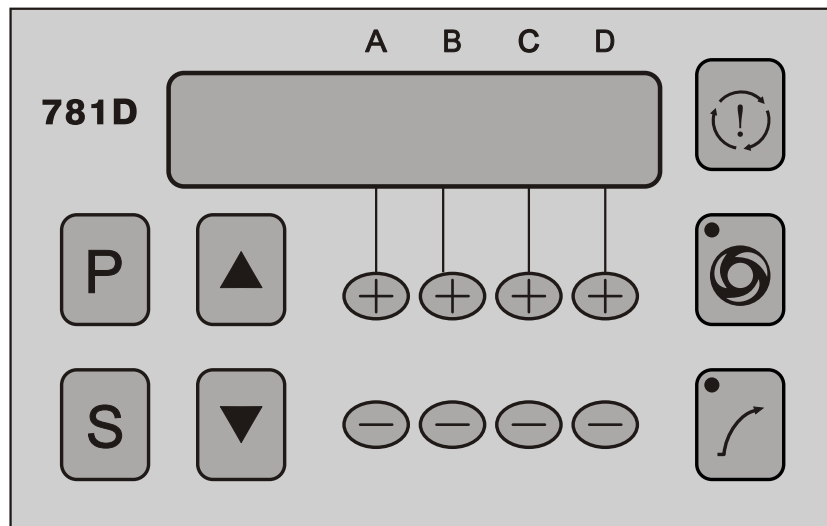

Key Functions

Functions	Keys	Action Description
Emergency stop button		During operation, press this key can immediately stop the current action
RESET		Perform a reset operation
(AUTO)		1. Do not press this button (LED not lit), the motor controlled by the pedal immediately. 2. Press this button (LED on), light step pedal, then automatically finish a keyhole feature.
Slow start		Slow start setting keys, LED light indicates ON, LED is not dark indicates off
Speed setting		Each time press this button, the speed increase of 50
		Each time press this button, the speed reduced by 50

V、 Parameter settings

The control system has a number of parameters can be modified, arranged in a certain order. The specific parameters of the project content, name, scope, content and setting the initial value numerical description see Appendix 5 "system function parameter list." Function parameters are divided into Zone A user parameters (including 1-45 numbers) and parameter B area (including 46-79 numbers), all parameters are set on the operation panel to achieve the general sewing operation interface shown in Figure 5-1.

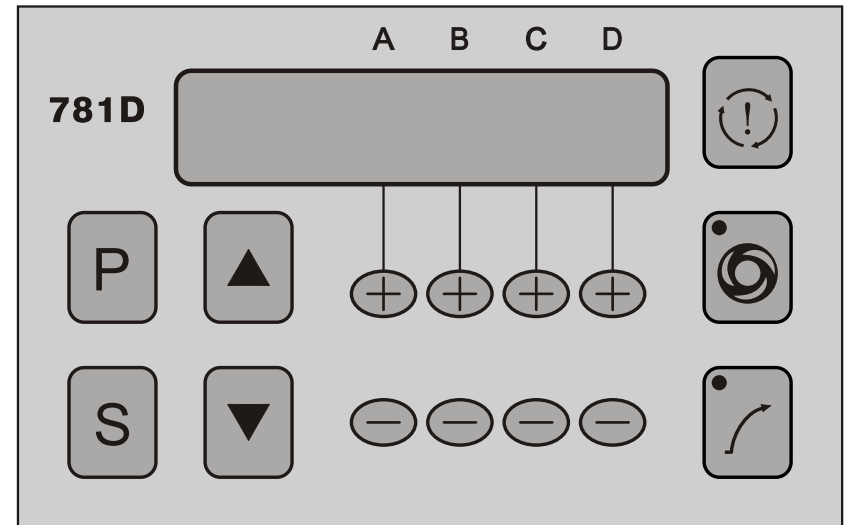

Figure 5-1 General sewing operation interface

1. How to enter area A use parameter

In general sewing operator interface (Figure 5-1) hold the programming button P for 2-3 seconds, the system enters the parameter setting interface, the user parameter area A (1-45 number parameter) to be modified, but not the B System parameters can be modified region.





2. How to enter the system parameters B,

Press and hold the P key, the system is powered on, the system starts to enter the parameter setting interface, in this state, zone A user parameter (No. 1-45) and B system parameters (No. 46-79) can be modified

3. Instructions for use parameter settings panel buttons

1) Key functions defined

The system enters the "parameter setting interface", the buttons on the operator panel is redefined, and the original meaning differ, specifically defined below

Key	Meaning	Remark
	Parameter number plus one	when press and hold on the parameter number has been continuously increasing
	Parameter number minus one	when press and hold on the parameter number has been continuously reducing
	The contents of the selected parameter number for viewing or saving	In the choose the right parameter number is then press this key to view or modify the parameter contents, after modify the parameter value then click this key to exit and save the parameters
	Enter or exit the function parameter editing	In general sewing interface press 2-3 seconds to enter the parameter edit mode, in the parameter edit mode this button for 2-3 seconds to exit parameter edit mode to normal sewing Interface
	Plus or minus key to modify the contents of the value parameter	A plus and minus keys to modify the corresponding multiples of 1000 B plus and minus keys to modify the corresponding multiples of 100 C plus and minus keys to modify the corresponding multiples of 10 D plus and minus keys to modify the corresponding multiples of 1

2) Panel Display Introduction

The operator panel has 6 digital display, in different states represent different significance.

In the parameter number selection screen (Figure 5-2) to display the parameter number and parameter name abbreviation code. The top three is the parameter number, followed by three shows the parameter name abbreviation. Figure 5-2, "001" as the parameter number, "H" is the parameter name, then press the S key to enter the parameter to modify the contents of the interface.

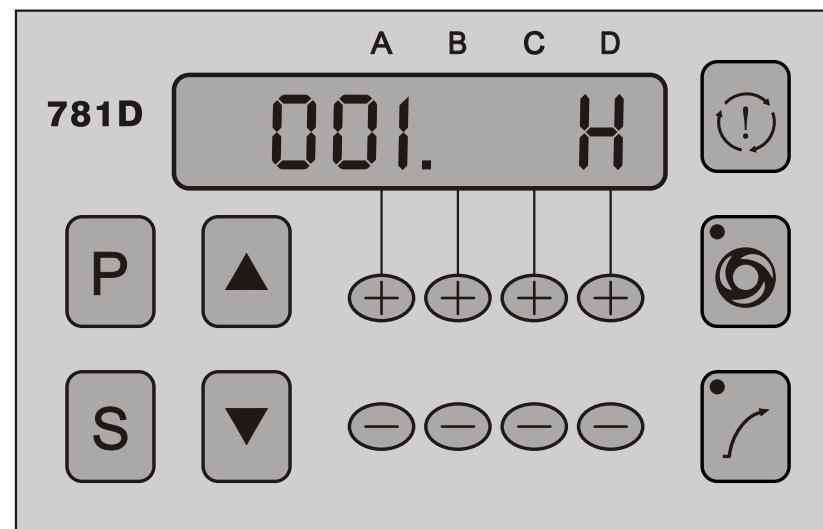

Figure 5-2, the maximum speed (user parameters 001.H) parameter number selection screen

In the enter parameter modification interface (Figure 5-3), the first 1-3 shows the parameter name in abbreviation, the number of bits occupied by the number of decisions by the acronym, 3-6 digit display specific parameter values, the number of bits occupied by the parameter determines the number of bits (if there are four parameter values, and its name is only an abbreviation of the parameter values are 3, and its name abbreviation 1-3 range). Figure 5-3, "H-bit" parameter name, 3000 as a parameter content, which means that the maximum speed when sewing set 3000R/MIN.

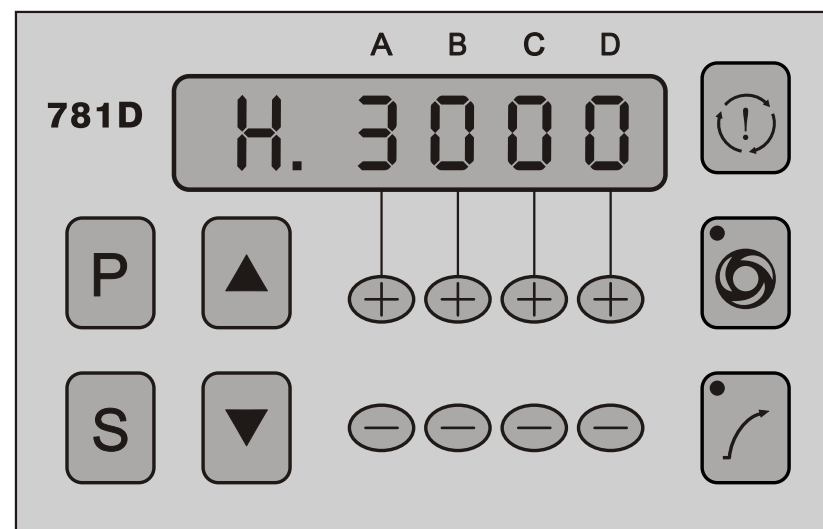

Figure 5-3, the maximum speed parameter contents modify interface

4. Parameter setting example

1) Such as setting "acceleration curve adjustment%" is 80, according to Appendix 5 "system function parameter list" can be found in "accelerated curves adjustment%" is located in Zone A user parameter "002.PSL".

2) Parameters Step 4.1 "How to Enter User parameters A zone" method, enter the user parameter A zone, use the or key to select the parameter number to "002.PSL", shown in Figure 5-4.

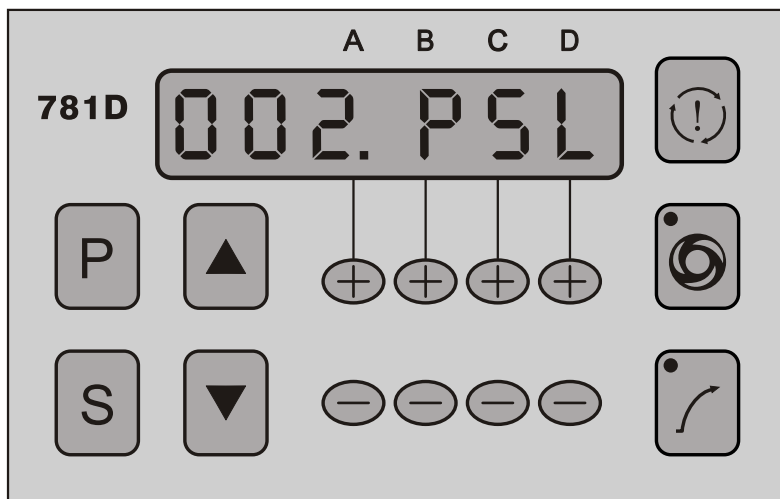

Figure 5-4, the acceleration curve adjustment% (user parameters 002.PSL) parameter number selection screen

3) Press S to enter the parameter to modify the contents of the interface, shown in Figure 5-5.

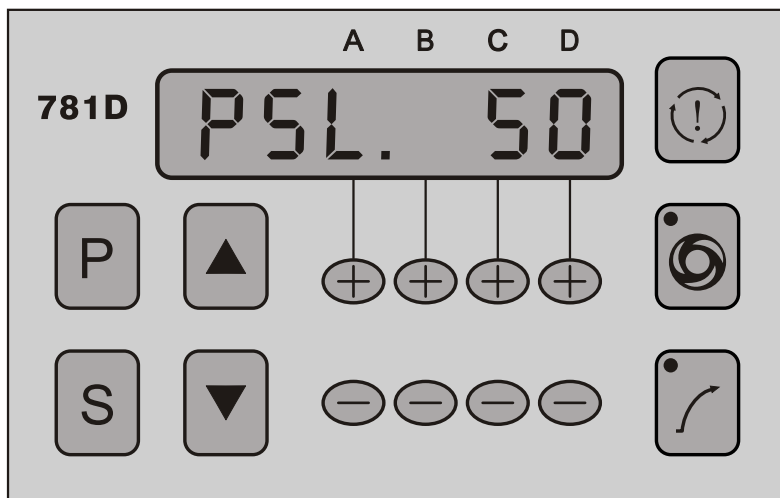

Figure 5-5, the acceleration curve adjustment% (user parameters 002.PSL) content of parameter selection screen.

- 4) Press the button on the front panel, modify the parameter content to 50.
- 5) Press S to save the parameter contents.
- 6) Press the P key for 2-3 seconds, exit to normal sewing interface.

5. Special Features

1) Machined piece number display:

Normal operating mode, press and hold S key to display "PN.002";

2) Automatic test function:

The parameter "005.TOT.056.TM1, 057.TM2, 058.UTD" setting enables automatic debugging. [055.TOT]: When UTD = ON, you can do its operation time limitation, set the range of 1 ~ 800HS, ie, the longest up to 33 days (800 hours);

[056.TM1]: When UTD = ON when testing the automatic operation, the working time range of free stitch setting is 1 ~ 60S, and sewing during automatic operation mode (free seam, fixed-inch sewing, tacking) from the operation panel needs to be set according to the test project

[057.TM2]: When UTD = ON when testing the automatic operation, set the time of interval stopped the motor, set the range of 1-60S.

[058.UTD]: automatic operation test function set, when this parameter is set to ON, the automatic operation start of the test, press the select key set sewing mode.

During the test, such as the need to modify the parameters of the above, the front step pedal and remain suspended automatic test, the parameters can be modified, when the pedal back to neutral position, the system will be a new set of modes and parameters proceed automatic test . In automatic operation after testing the foot the pedal backside or set 058.UTD to OFF, you can exit the automated tests.

6.The default parameters are restored

1) Hold on the S key, the system power, after the panel displays two data changed to "08" (note "0" is not displayed)

2) Hold on the S key moment, set panel displays the parameter number changed to "096.RS".

3) Then hold on the S key, the contents of the parameter to "5550" and then press the S key to confirm exit

Appendix 1

Operation Panel

1. Parameter number selection interface (001.H)

As shown, the maximum speed parameter number 001.H:

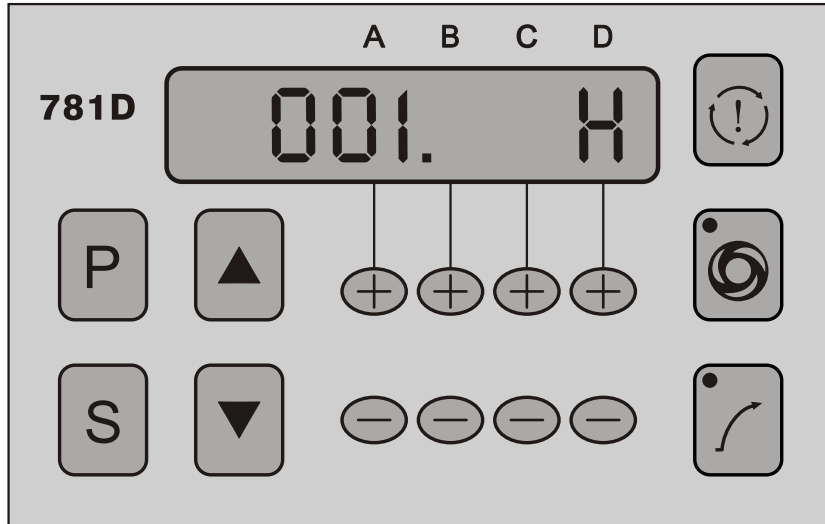

2. Content Modification Interface Parameters

As shown, the maximum speed parameter entry 001.H modified interface: 001.H = 3000r/min

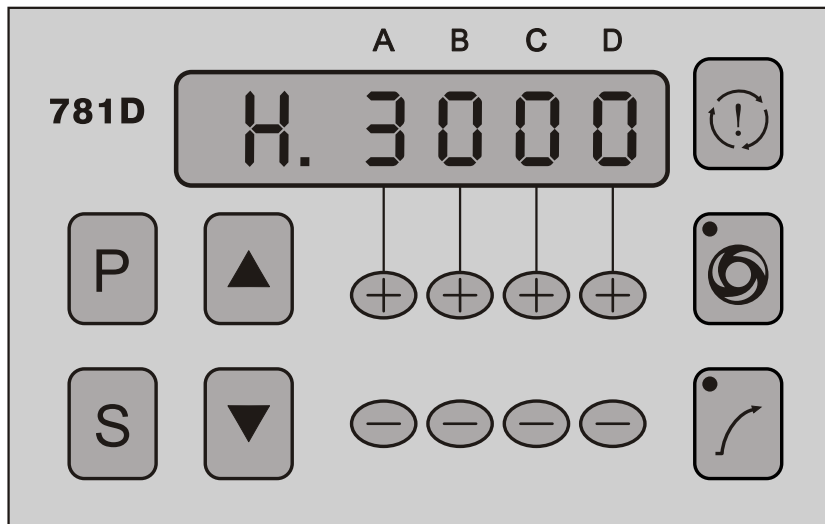

Appendix 2

Seven segment display font and font actual value comparison table

1. Digital Fonts section

Actual value	0	1	2	3	4	5	6	7	8	9
LCD	0	1	2	3	4	5	6	7	8	9

2. English font section

Alphabet	A	B	C	D	E	F	G	H	I	J
LCD	A	b	C	d	E	F	G	H	I	J
Alphabet	K	L	M	N	O	P	Q	R	S	T
LCD	t	L	n	n	o	P	q	r	S	t
Alphabet	U	V	W	X	Y	Z				
LCD	U	v	W	X	Y	Z				

Appendix 3 Power cord connection method

1. 220V power connection

Yellow-green wire is the ground wire, must ensure reliable grounding

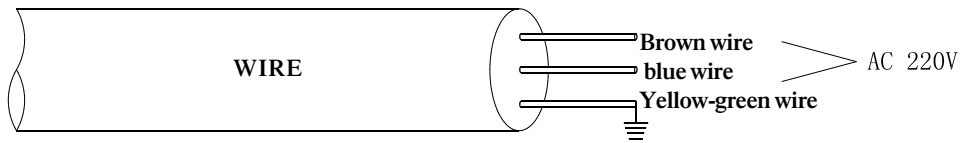

2. 380V three-phase four-wire power connection

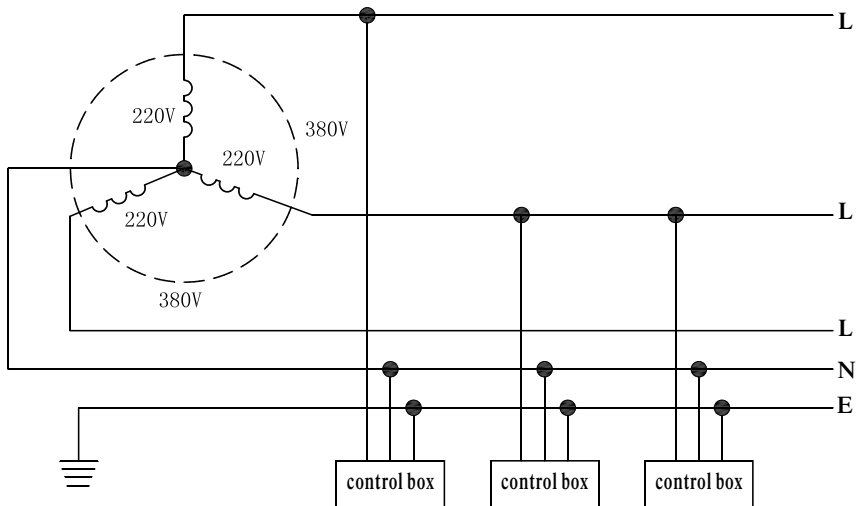

Appendix 4 Terminal Block Function Chart

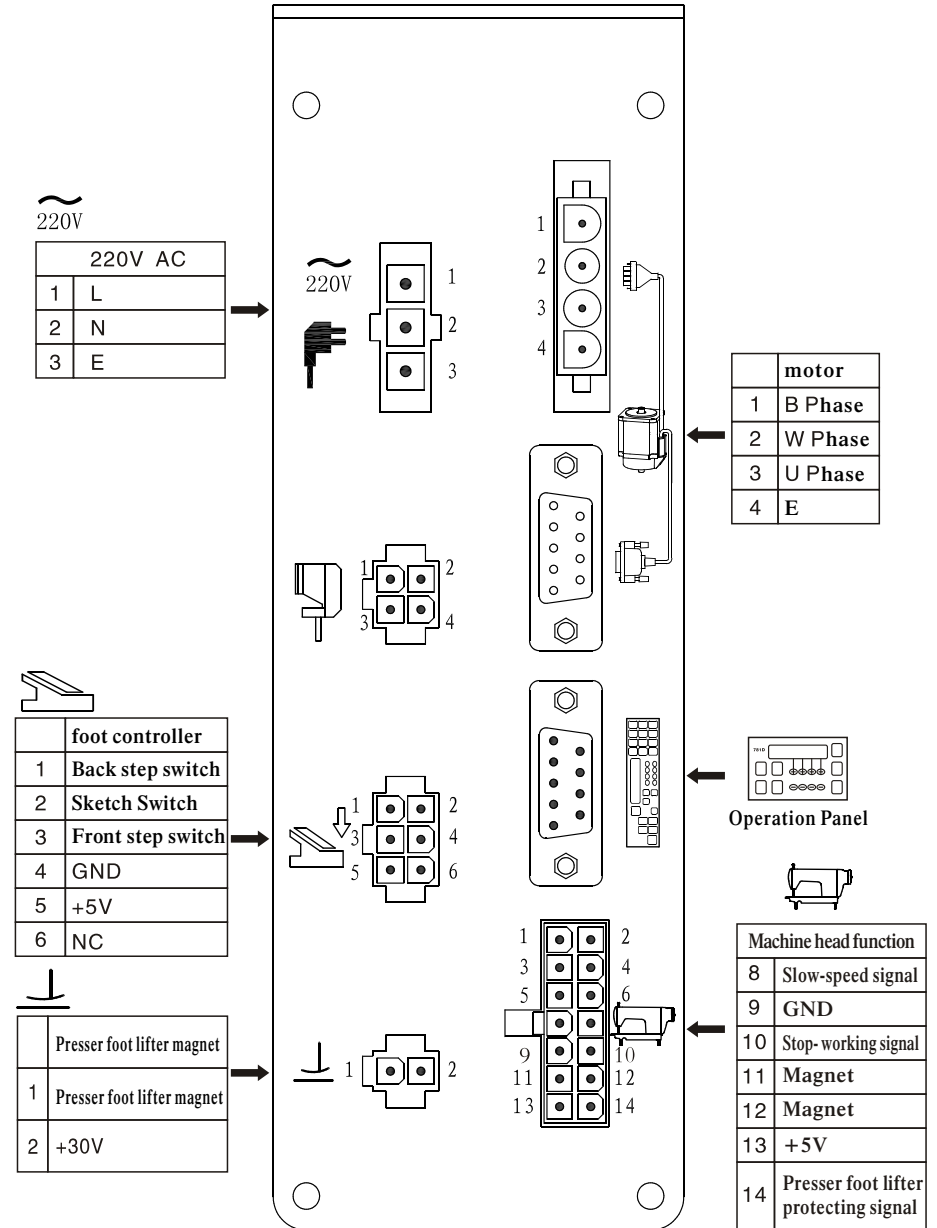

Appendix 5 System function parameter list

1. A user parameter area

Parameters Item Description	Name	RANGE	Initial value	Set Property Value Description
[001. H]	Maximum speed r/min	150~3000	2000	The highest speed setting when sewing with related models
[002.PSL]	Acceleration curve adjustment	1~100%	80%	Climb slope of the acceleration controller settings
[005. V]	End the reverse sewing speed r/min	150~2800	1800	End the reverse sewing speed adjustment
[007. S]	soft start sewing speed r/min	150~2800	400	soft start sewing speed adjustment
[008.SLS]	soft start sewing stitch number	0~99 Stitch	2	soft start sewing stitch number adjustment
[009. A]	Automatic stitch sewing speed setting r/min	300~3000	2000	AUTO operation panel keys are pressed for speed setting

System parameters B

Parameters Item Description	Name	RANGE	Initial value	Set Property Value Description
[046.DIR]	Motor rotation direction setting (Reversible)	CW/CCW	CCW	CCW: Counterclockwise CW: Clockwise
[048.SYM]	Synchronizer model set	0~2	2	Hohsing H-Sync is compatible with hohsing 1: B-type synchronizer, improved synchronization 2: D-type synchronizer, direct drive configuration DB9 port, no synchronizer installation of electrical self-test signal lines. The needle upper position, the needle down position encoder signal collinear
[054. BK]	The motor is stopped, the brake lock function	OFF/ON	ON	ON: The motor is stopped, the brake lock machine OFF: No effect

[055.TOT]	UTD = ON, the motor running total time limit	1~800Hrs	8	Up to 33 days (800 hours)
[056.TM1]	UTD = ON, the motor running time	1~60s	3	In automatic operation test, the working hours of free sewing
[057.TM2]	UTD = ON, the motor stop time	1~60s	3	In automatic operation test, each time interval
[058.UTD]	Automatic operation test function	OFF/ON	OFF	This parameter is set to ON, the automatic operation start of the testing, according to the sewing needle selection box set mode
[059. T]	Trimming, stopping speed setting r/min	120~500	500	Trimming stopping speed adjustment, the speed is too low may lead to normal trimming speed ,too high may lead to unstable positioning control
[060. L]	Low speed r/min	120~400	500	Low speed adjustment
[062. PC]	Presser foot, back seam movement cycle signal	10~90	25	Presser foot, tacking action to periodic power output, avoid hot presser
[063. FD]	Delayed motor starting, protection the presser foot release time	0~990	50	Depress the time delay start time to tie the confirmation of the presser foot down
[075.UEG]	Stop when the needle upper stop position adjustment	5~250	40	Fine-tuning stops positioned on the angular position (center value is 40), the value decreased needle in advance, the value increases will be delayed needle
[077.ANU]	Power on and automatic to seek upper needle stop position	OFF/ON	ON	ON: After power is turned on, automatically find the positioning signal to stop OFF: No effect
[079.ERR]	Last fault error code	0~999	0	0—No fault occurred

Note: The servo system functions to read and modify the parameters detailed instructions, see the keyboard operability in this manual "5. Parameter Settings" section

Appendix 6 System failure alarm code and troubleshooting

High-speed sewing machine control system has automatic alarm function in the event of failure, the controller will issue a "bit" beep while on the operation panel will display the corresponding error code, then the controller automatically starts saver, stop all sewing function, to avoid accidents.

The meaning of the fault code and the possible problems and solutions as follows:

Error Codes	Code Meaning	Possible Problems	Remedy	
Fatal Error	ERR-00	Input signal self-test error	<ol style="list-style-type: none"> 1. Foot pedal speed control circuit problem or pedal power has been in self-test front step and back step state can not return to the neutral position; 2. DC bus voltage is low; 3. Driver module fault signal is not normal. 	<ol style="list-style-type: none"> 1. Release the foot pedal back to the neutral position; 2. Check the pedal signal cables are connected well;
	ERR-01	Machine body feedback signal is not normal	<ol style="list-style-type: none"> 1. Synchronizer is not normal, the needle upper position can not be detected; 2. Sensor magnet off; 	
	PWROFF	Power off	<ol style="list-style-type: none"> 1. 30W Fuse failure; 2. System is powered down. 	Power off, check all fuses, re-power
	ERR-03	The machine is not running properly	<ol style="list-style-type: none"> 1. Synchronizer is not normal, the needle below position can not be detected; 2. Sensor magnet off; 	
	ERR-04	Overcurrent, overvoltage, overtemperature, undervoltage	<ol style="list-style-type: none"> 1. Motor power drive module Fault; 2. Instantaneous interference. 	
	ERR-05	DC bus voltage overvoltage	<ol style="list-style-type: none"> 1. Braking resistor or braking bad fuse; 2. Instantaneous interference. 	Power off the system checks
	ERR-06	Electromagnet power supply overcurrent	<ol style="list-style-type: none"> 1. Magnet overload or short; 2. Drive circuit fault; 3. Instantaneous interference. 	Power off the system checks
	ERR-07	Stuck	<ol style="list-style-type: none"> 1. Mechanical stuck; 2. Trimmer system have a problem; 3. The encoder signal is not normal; 4. Motor output HALL signal is not normal. 	Power off the system testing machine checks whether the normal mechanical properties

General warning	9	DC bus voltage is too low	<ol style="list-style-type: none"> 1. AC input voltage is too low; 2. There is a fault Inside. 	Supply voltage detection
	A	Positioning parking error	<ol style="list-style-type: none"> 1. MPD、SPD parameter setting wrong; 2. Overload; 3. The encoder signal is not normal; 4. Synchronizer signal instability; 5. Motor failure, lack of driving force. 	Power off, check the machine and the motor is normal or not
	B	Exceed the maximum speed	<ol style="list-style-type: none"> 1. Exceed the maximum speed in the same direction; 2. Exceed the maximum speed in the same direction; 3. The encoder signal is not normal; 4. Motor output HALL signal is not normal; 5. Motor failure (such as demagnetization). 	<ol style="list-style-type: none"> 1. Between the control box and the motor drive line U / V / W connections are good or not; 2. Whether the system has been reliably grounded.
	C	Synchronizer self-test error	Synchronizer is not plugged in	<ol style="list-style-type: none"> 1. Power off, plug in the synchronizer, and then power on; 2. Replace synchronizer
	D	Eeprom read and write data error	Eeprom parameter storage problems	Replace eeprom
	E	Set the parameters in eeprom error	The eeprom setting parameter is incorrect	Power Restart
	F	Motor encoder output signal error	If the "F" continuous alarm indicates that the motor built-in encoder problem.	Check the motor output signal line is disconnected or bad

When a fault occurs, firstly power off the system, check the control system ground is good, after 30 seconds, restart the system and see if the power can work, if the fault does not clear, please try again, still not clear, please contact the supplier.

Appendix7 PACKING LIST

No.	Name	Number	Unit	Remark
1	Servo controller	1	Pcs	
2	Servo motor	1	Pcs	
3	Operation Box	1	Pcs	
4	Pedal rod set	1	Set	
5	Setscrew for mounting motor	1	Set	
6	AC Power switch	1	Set	
7	Synchronizer	1	Set	
8	Setscrew	1	Set	
9	User Manual	1	Copy	

Appendix 8 The appearance of the product Cleaning Instructions

If necessary, make the product casing cleaning operations, please turn off the power and unplug the power cord, wait 10 minutes use the medication cotton dipped in alcohol moderately scrub, but can not make the alcohol flows through the cracks inflo connectors and internal chassis, in order to avoid a conductive impurities into the box, and make the impact on electrical use. In the natural drying, plug in the power working

Appendix 9 Description of the product casing open

Under normal circumstances, if any, need to open the control box housing shall be trained to perform electrical and mechanical technicians, and must use insulated protective tools, assembly screws, etc. shall not be removed by hand, in case of emergency.

Appendix 10 Replacement parts for this product declaration

The following parts need by the company or agency designated by the Company to provide and replace, such as replaceable and all the consequences, the Company does not assume any responsibility.

Number	Name
1	Power board (model NO: PS2202)
2	Main board (model NO: MC2102)
3	Power input board (model NO: PFV2202)
4	Braking resistor (160Ω/ 60 W)
5	Operation Panel
6	Foot Control Box
7	Synchronizer
8	Servo motor machine input and output interfaces
9	Controller shell (aluminum die casting, plastic parts, sheet metal parts, etc.)
10	Controller associated with a variety of electrical control cable